

DATASHEET AND OPERATING GUIDE

USBKIT

USB Interface Kit

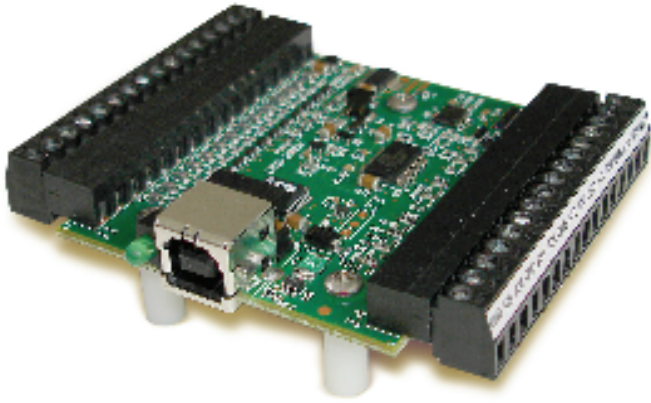

FEATURES AND BENEFITS

- Includes Digital-to-Analog (D/A) converter for remote setpoint control of laser driver or temperature controller
- Analog-to-Digital (A/D) converters are used to monitor actual laser diode current or temperature
- Auxiliary A/D can be configured as a single 14-bit differential input or two 13-bit single-ended inputs
- Software can control one laser diode driver, one temperature controller, an auxiliary monitor, and provides full graphing and datalogging
- Save multiple setups for easy repeatable experiments or manufacturing testing

COMPUTERIZE THE WAVELENGTH ADVANTAGE

Expand the capabilities of your Wavelength Electronics drivers and controllers with the USBKIT and QuickConnect™ software. The USBKIT provides convenient computer control of most Wavelength chassis mount controllers and PCB-mounted devices with evaluation boards.

The software provides an intuitive virtual control panel that allows you to leverage the low-noise, high-stability laser diode and temperature control capabilities of Wavelength's components to save time and money.

PLUG-IN CONVENIENCE FOR OEMS

Build the USBKIT into your OEM laser system and enjoy the convenience of closed-cover system calibration and troubleshooting—all you need is the USB cable that comes with the USBKIT.

The software is built on the Windows .NET framework so you can write your own code for a manufacturing test system, a field-calibration kit, or for laboratory applications.

CONTENTS	PAGE
QUICKCONNECT™ QUICK START	2
USBKIT FUNCTIONS AND COMPATIBILITY	2
PIN DESCRIPTIONS	3
SPECIFICATIONS	4
SAFETY INFORMATION	5
SOFTWARE INSTALLATION INSTRUCTIONS	6
OPERATING INSTRUCTIONS	8
ADDITIONAL TECHNICAL INFORMATION	18
TROUBLESHOOTING	22
MECHANICAL SPECIFICATIONS	23
CERTIFICATION AND WARRANTY	24

ORDERING INFORMATION

PART NO	DESCRIPTION
USBKIT	Customized National Instruments D/A card, plus QuickConnect™ software

406-587-4910
www.teamWavelength.com

Applies to Product Revisions A-C
 © April 2016



QUICKCONNECT™ QUICK START

Review the entire datasheet before operating the USBKIT and the QuickConnect™ Software.

- Load National Instruments NI-DAQ software, Microsoft .NET Framework, and Wavelength's QuickConnect™ application from the included CD. (See **page 6**)
- Connect USBKIT to PC using the included USB cable.
- Start QuickConnect™. Use Ctrl-O to open a device and select the USBKIT that is attached to the computer. (See **page 8**.) Multiple USBKITS can be connected to one computer.
- Select the Wavelength product, and wire it according to the onscreen diagram. An example wiring diagram is shown in **Figure 1**, at right. The wiring diagram displayed in the software is determined by the controller that is selected. All product wiring diagrams can be found in the Additional Technical Information section (**page 18**).
- Select and calibrate the temperature sensor, and set up the optional temperature limits. (See **page 10**.)
- Select the laser diode driver model and wire it according to the onscreen diagram. (See **page 14**.)
- Wire one auxiliary signal differentially (14-bit resolution) or two signals in single-ended mode (each with 13-bit resolution). (See **page 15**.)
- Select which fields to display in the onscreen strip charts. (See **page 16**.)
- Select which data fields to log, and enter the file name.
- Save the settings to a Configuration file if the same setup will be used again in the future.

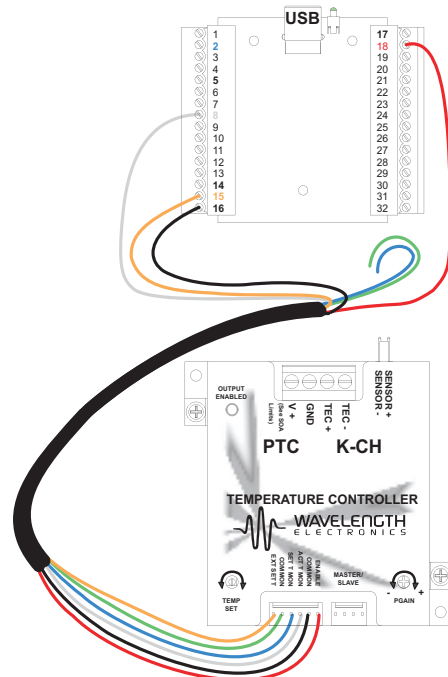

Figure 1. Example Wiring Diagram



SPECIAL ATTENTION TO ELECTRICAL GROUNDING IS REQUIRED WHEN USING THE USBKIT. REFER TO **PAGE 18** FOR DETAILS.

USBKIT FUNCTIONS AND COMPATIBILITY

PRODUCT FAMILY	PRODUCTS	TEMPERATURE SETPOINT CONTROL	TEMPERATURE CONTROLLER ENABLE	ACTUAL TEMPERATURE MONITOR	TEMPERATURE SETPOINT MONITOR	LASER SETPOINT CONTROL	LASER OUTPUT ENABLE	ACTUAL LASER CURRENT MONITOR	PD CURRENT MONITOR	LASER CURRENT LIMIT MONITOR	LIMIT STATUS
PTC-CH Family	PTC2.5K-CH PTC5K-CH PTC10K-CH	X	X	X	-	-	-	-	-	-	-
PTC PCB Family	PTC5000 PTC10000	X	X	X	-	-	-	-	-	-	-
LDTC 2-2 Family	LDTC 2-2 0 LDTC 2-2 E	X	-	X	X	X	X	X	X	-	-
LDTCxx20 Family	LDTC0520 LDTC1020	X	-	X	X	X	X	X	X	-	-
PLD-CH Family	PLD5K-CH PLD10K-CH PLD12.5K-CH	-	-	-	-	X	X	X	X	X	X
PLD PCB Family	PLD200 + EVAL PLD500 + EVAL PLD1250 + EVAL PLD5000 + EVAL PLD6500 + EVAL	-	-	-	-	X	X	X	X	X	X
PLD10EV	PLD10000 + EVAL PLD12500 + EVAL	-	-	-	-	X	X	X	X	X	X

Other Wavelength products can be interfaced to the USBKIT. Contact the factory for details.

PIN DESCRIPTIONS

Table 1. Pin Descriptions

PIN	NAME	FUNCTION	PIN DESCRIPTION
2	AI.0	Input	LD Current Monitor; 14-bit analog input, referenced to ground
5	AI.1	Input	PD Current Monitor; 13-bit analog input, referenced to ground
6	AI.5	Input	LD Current Limit Monitor; 13-bit analog input, referenced to ground
8	AI.2	Input	Actual Temperature Monitor, 13-bit analog input, referenced to ground
9	AI.6	Input	Temperature Setpoint Monitor, 13-bit analog input, referenced to ground [Rev. A & Rev. B this pin was ground.]
11	AI.3	Aux Monitor	Aux Monitor 1; 13-bit single-ended or 14-bit differential analog input (see page 15)
12	AI.7	Aux Monitor	Aux Monitor 2; 13-bit single-ended or 14-bit differential analog input (see page 15)
13	GND	Ground	Ground connection for Aux Monitor inputs
14	AO.0	Output	LD Setpoint; 12-bit analog output
15	AO.1	Output	Temperature Controller Setpoint; 12-bit analog output
16	GND	Ground	Ground connection for the LD and TC Setpoints
17	PO.0	Output	LD Enable; digital output
18	PO.1	Output	Temperature Controller Enable; digital output
19	PO.2	Input	Limit Status Monitor, digital input

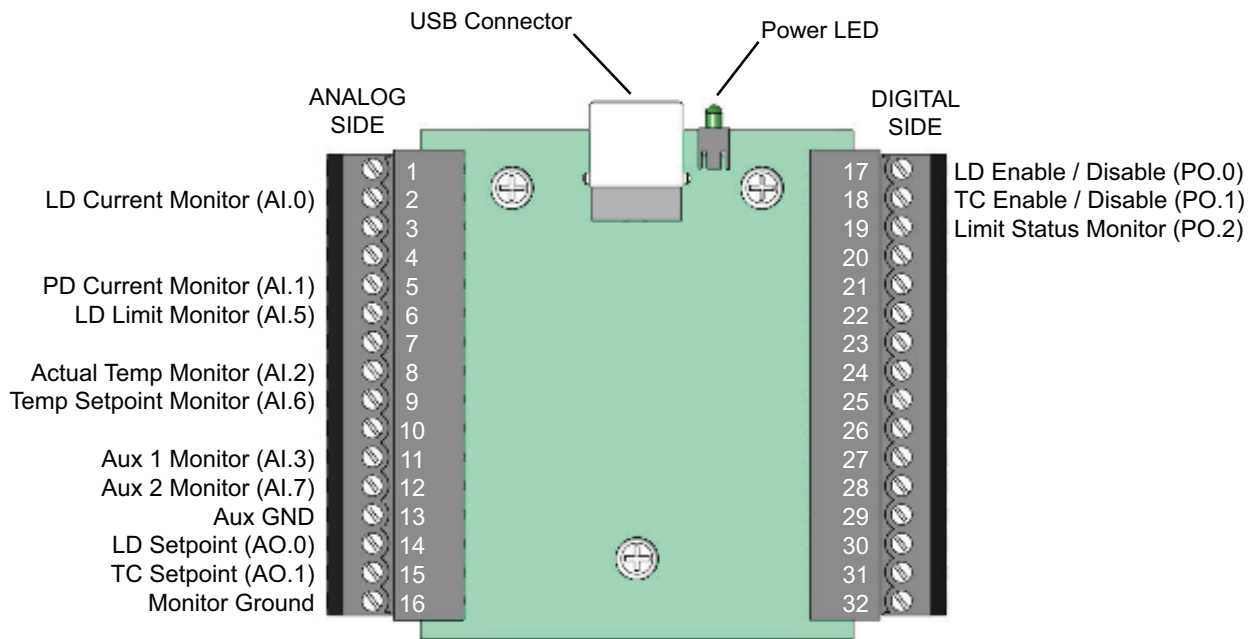

Figure 2. USBKIT Top View

Table 2. Hardware and Software Revision Compatibility

HARDWARE REVISION	SOFTWARE REVISION	RESULT
C	2.2 or earlier	ACT T MON is not valid. Ground SET T MON (Pin 9) to restore ACT T MON.
A or B	2.3.5 or later	SET T MON will always read zero (0).

SPECIFICATIONS

PARAMETER	VALUE	UNIT	NOTE
Size	3.2 x 2.8 x 1.2	in	81.3 x 71.1 x 30.5 mm
Weight	2	oz	56 grams
Supply Voltage	USB Bus Powered		
USB Interface	Full Speed, Self-Powered USB 2.0		
Operating Temperature	0 to 55	°C	
Storage Temperature	-40 to 85	°C	
A/D Resolution	13 bits (x2) or 14 bits (x1)		(2x) Single-ended inputs or (1x) Differential input
D/A Resolution	12	bits	(x2) outputs available; for setpoint control of laser driver and temperature controller

COMPUTER SYSTEM REQUIREMENTS

Operating System Compatibility (US English Edition)		
	x86 (32-bit)	x64 (64-bit)
Windows 7	X	X
Windows Vista	X	X
Windows XP SP3	X	
Installation Prerequisites QuickConnect version 2.3.6 and earlier (Available for free from Microsoft and National Instruments websites.)	.NET Framework 4.0 NI-DAQmx 9.6.x	
Installation Prerequisites QuickConnect version 2.4.0 and later	.NET Framework 4.0 NI-DAQmx 15.1.1f3	
Memory	256 MB Minimum	