

100G CFP SR10 400m Optical Transceiver GCF-M101-SR10C

Features

- ◆ Compliant to the CFP Hardware Specification Version 1.4
- ◆ Compliant to the CFP MSA Management Interface Specification Version 2.2
- ◆ Compliant to the IEEE 802.3ba (100GBASE-SR10)
- ◆ Transmission data rate up to 11.18Gb/s per channel
- ◆ Up to 300m on OM3 and 400m on OM4 MMF
- ◆ Power class 1 (<8W max)
- ◆ OTU4 compatible
- ◆ 10 channels 850nm VCSEL array transmitter
- ◆ 10 channels PIN photo detector array receiver
- ◆ MDIO digital diagnostic interface and control capabilities.
- ◆ TX input and RX output CDR retiming
- ◆ Hot pluggable electrical interface
- ◆ Operating case temperature:0°C~ +70°C
- ◆ Single 3.3V power supply
- ◆ RoHS 6 compliant(lead free)
- ◆ Utilizes a standard 24/20 lane optical fiber with MPO connector



Applications

- ◆ 100GBE interconnects
- ◆ High-speed core router connections & Datacom/Telecom switch
- ◆ Data aggregation and backplane applications
- ◆ Proprietary protocol and density application

Description

The CFP optical transceiver module is a high performance, low power consumption, short reach (up to 400m) interconnect solution supporting 100G Ethernet and Telecom. It is compliant with the CFP MSA and IEEE P802.3ba 100GBASE-SR10. Gigalight CFP SR10 modules offer 10 transmit and 10 receive asynchronous channels operating at up to 11.18Gb/s per channel.

As shown in Figure 1, the transmitter side of the module consists of an array of VCSELs (Vertical Cavity Surface Emitting Lasers) and associated circuitry, which converts 10 parallel electrical data inputs to 10 parallel optical data output signals and also converts 10 parallel optical signals into 10 parallel electrical signals through an array of PIN photodiodes and associated circuitry. The refclk clock of 161.1328M for 100GE (or 174.6875M for OTU4) is necessary for our module (Optional).

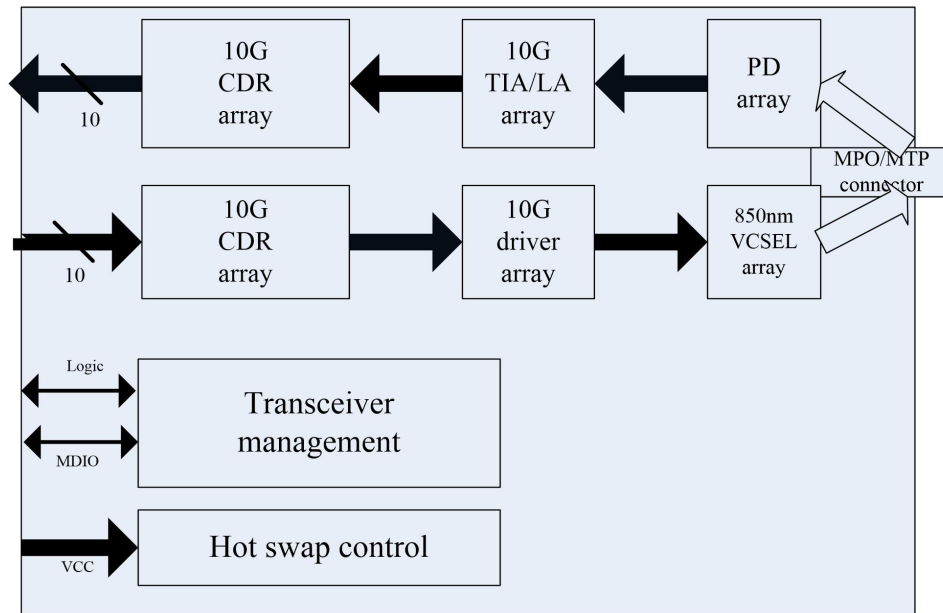

Figure1.Module Block Diagram

Absolute Maximum Ratings

Parameter	Symbol	Min	Max	Unit
Supply Voltage	Vcc	-0.5	3.6	V
Input Voltage	Vin	-0.3	Vcc+0.3	V
Storage Temperature	Tst	-40	85	°C
Humidity(non-condensing)	Rh	5	85	%

*Exceeding any one of these values may destroy the device immediately

Recommended Operating Conditions

Parameter	Symbol	Min	Typical	Max	Unit
Supply Voltage	Vcc	3.13	3.3	3.47	V
Operating Case temperature	Tca	0		70	°C
Data Rate Per Lane	fd	-	10.3125	11.18	Gbps

Power Dissipation	Pm			8	W
Low Power Mode Dissipation	Plow			2	W
Aggregate Bit Rate	BRaggr		103.125	111.8	Gbps

Electrical Characteristics

Parameter	Symbol	Min	Typical	Max	Unit	Notes
Differential input impedance	Zin	90	100	110	ohm	
Differential Output impedance	Zout	90	100	110	ohm	
Differential input voltage amplitude	ΔV_{in}	120		820	mVp-p	
Differential output voltage amplitude	ΔV_{out}	300		820	mVp-p	
Input Logic Level High	VIH	2.0		VCC+0.3	V	3.3V LVCOMS
		0.84		1.2	V	1.2V LVCOMS
Input Logic Level Low	VIL	-0.3		0.8	V	3.3V LVCOMS
		-0.3		0.36	V	1.2V LVCOMS
Output Logic Level High	VOH	VCC-0.2		VCC	V	3.3V LVCOMS
		1.0		1.5	V	1.2V LVCOMS
Output Logic Level Low	VOL	0		0.2	V	3.3V LVCOMS
		-0.3		0.2	V	1.2V LVCOMS

Note:

1. Differential input voltage amplitude is measured between TxnP and TxnN.
2. Differential output voltage amplitude is measured between RxnP and RxnN.

Optical Characteristics

Transmitter Optical Specifications (T = 25°C, VCC = 3.3V +/- 5%)

Parameter	Symbol	Min	Typical	Max	Unit
Average Optical Power(per channel)	Pout	-7.6	-1	+2.4	dBm
Average Optical Power(per channel) - Disabled	Poff			-30	dBm
Optical Return Loss Tolerance				12	dB
Extinction Ratio	ER	3			dB
Center Wavelength	λ_c	840	850	860	nm
RMS Spectral Width	λ		0.5	0.65	nm
Transmit OMA,per Lane	TX_OMA/lane	-5.6		3	dBm
Difference in launch power between any two lanes(OMA)				4	dB
Transmitter and dispersion penalty,each lane	TDP/lane			3.5	dB
Transmitter eye mask	Compliant to IEEE802.3ba eye mask specification				

Note:

1. Average optical power is measured at the output of the modules optical interface.

Receiver Optical Specifications (T = 25°C, VCC = 3.3V +/- 5%)

Parameter	Symbol	Min	Typical	Max	Unit
Optical Power Sensitivity(per channel)	Pin min	-	-12	-9.9	dBm
Optical Power Saturation(per channel)	Pin max	+2.4dBm	-	-	dBm
Stressed Receiver Sensitivity	P _s	-	-	-5.4	dBm
Center Wavelength	λ _c	840	850	860	nm
RMS Spectral Width	λ		0.5	0.65	nm
Optical Return Loss	RI	12			dB
Damage Threshold		+3.4dBm			dBm
Optical modulation amplitude, each lane				3	dBm

Note:

1. Optical power sensitivity is measured with BER@10⁻¹² at 10.3125Gbps per channel.

CFP module functional block diagram

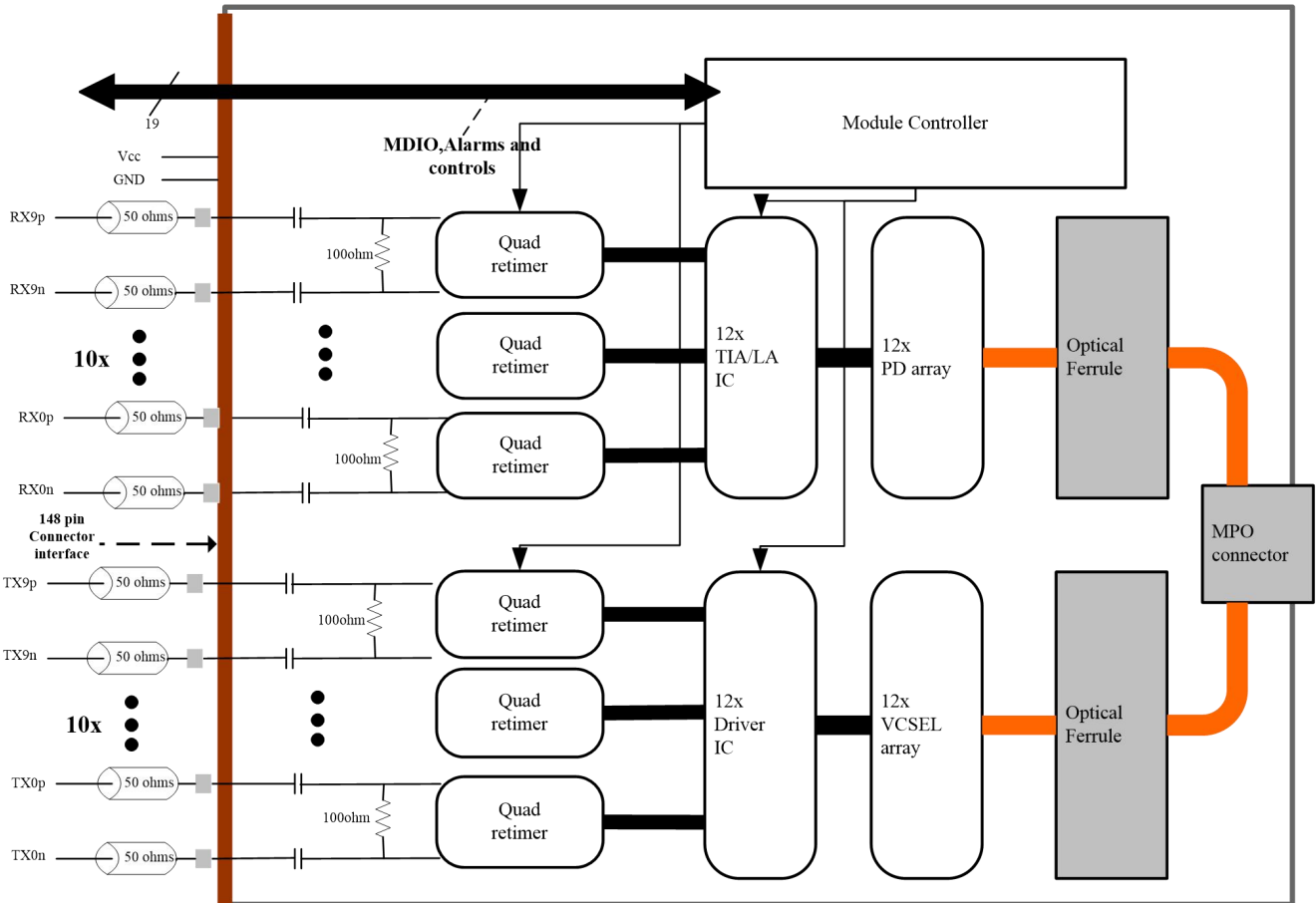

Figure2. CFP module functional block diagram

Pin Descriptions

Part A: Bottom Row Pin Function Definition

Pin	Symbol	Type	I/O	Description
1	3.3V_GND	GND		3.3V Module Supply Voltage Return Ground, can be separate or tied together with Signal Ground
2	3.3V_GND	GND		
3	3.3V_GND	GND		
4	3.3V_GND	GND		
5	3.3V_GND	GND		
6	3.3V	VCC		3.3V Module Supply
7	3.3V	VCC		
8	3.3V	VCC		
9	3.3V	VCC		
10	3.3V	VCC		
11	3.3V	VCC		
12	3.3V	VCC		
13	3.3V	VCC		
14	3.3V	VCC		
15	3.3V	VCC		
16	3.3V_GND	GND		
17	3.3V_GND	GND		
18	3.3V_GND	GND		
19	3.3V_GND	GND		
20	3.3V_GND	GND		
21	NC		I/O	Gigalight internal, do not connect
22	NC		I/O	Gigalight internal, do not connect
23	GND	GND		
24	(TX_MCLKn)	CML	O	CML For optical waveform testing. Not used.
25	(TX_MCLKp)	CML	O	CML For optical waveform testing. Not used.
26	GND	GND		
27	NC		I/O	Gigalight internal, do not connect
28	NC		I/O	Gigalight internal, do not connect
29	NC		I/O	Gigalight internal, do not connect
30	PRG_CNTL1	LVC MOS w/PU	I	Programmable Control 1 set via MDIO, MSA default: TRXIC_RSTn – TX & RX IC reset. “0” = reset, “1” or NC = enabled or not used
31	PRG_CNTL2	LVC MOS w/PU	I	Programmable Control 2 set via MDIO, MSA default: Hardware power Interlock LSB, “00” = <8W, “01” = <16W, “10” < 24W, “11” or NC = >24W or not used
32	PRG_CNTL3	LVC MOS w/PU	I	Programmable Control 3 set via MDIO, MSA default: Hardware power Interlock MSB, “00” = <8W, “01” = <16W, “10” < 24W, “11” or NC = >24W or not used

33	PRG_ALARM1	LVC MOS	O	Programmable Alarm 1 set via MDIO, Reflex default: HIPWR_ON, Module power on indicator. "1" = Module high power up completed, "0" = Module not high powered up
34	PRG_ALARM2	LVC MOS	O	Programmable Alarm 2 set via MDIO, Reflex default: MOD_READY, module initialization complete, "1" = complete, "0" = not complete
35	PRG_ALARM3	LVC MOS	O	Programmable Alarm 3 set via MDIO, Reflex default: MOD_FAULT, module fault detected, "1" = fault, "0" = no fault
36	TX_DIS	LVC MOS w/PU	I	Transmitter Disable for all channels, "1" or NC = transmitter disabled, "0" = transmitter enabled
37	MOD_LOPWR	LVC MOS w/PU	I	Module low power mode. "1" or NC = module in low power (safe) mode, "0" = power-on enabled
38	MOD_ABS	GND	O	Module Absent. "1" or NC = Module absent, "0" = module present. Pull-up resistor on Host
39	MOD_RSTn	LVC MOS w/PD	I	Module Reset. "0" = reset the module, "1" or NC = module enabled, Pull Down resistor in module
40	RX_LOS	LVC MOS	O	Receiver loss of optical signal on any channel, "1" = loss of signal, "0" = normal condition
41	GLB_ALRMn	LVC MOS	O	Global Alarm. "0" = alarm condition in any MDIO alarm register, "1" = no alarm
42	PRTADR4	1.2V CMOS	I	MDIO port address bit 4
43	PRTADR3	1.2V CMOS	I	MDIO port address bit 3
44	PRTADR2	1.2V CMOS	I	MDIO port address bit 2
45	PRTADR1	1.2V CMOS	I	MDIO port address bit 1
46	PRTADR0	1.2V CMOS	I	MDIO port address bit 0
47	MDIO	1.2V CMOS	I/O	Management Data I/O bi-directional data (electrical specs as per 802.3ae)
48	MDC	1.2V CMOS	I	Management data clock (electrical specs as per 802.3ae)
49	GND	GND		
50	NC		I/O	Gigalight internal, do not connect
51	NC		I/O	Gigalight internal, do not connect
52	GND	GND		
53	NC		I/O	Gigalight internal, do not connect
54	NC		I/O	Gigalight internal, do not connect
55	3.3V_GND	GND		3.3V Module Supply Voltage Return Ground, can be separate or tied together with Signal Ground
56	3.3V_GND	GND		
57	3.3V_GND	GND		
58	3.3V_GND	GND		
59	3.3V_GND	GND		
60	3.3V	VCC		3.3V Module Supply
61	3.3V	VCC		
62	3.3V	VCC		
63	3.3V	VCC		
64	3.3V	VCC		
65	3.3V	VCC		
66	3.3V	VCC		
67	3.3V	VCC		

68	3.3V	VCC		
69	3.3V	VCC		
70	3.3V_GND	GND		
71	3.3V_GND	GND		
72	3.3V_GND	GND		
73	3.3V_GND	GND		
74	3.3V_GND	GND		

Part b:Top Row Pin Function Definition

Pin	Symbol		Pin	Symbol
148	GND		111	GND
147	Refclk_n		110	Not used
146	Refclk_p		109	Not used
145	GND		108	GND
144	Not used		107	RX9_n
143	Not used		106	RX9_p
142	GND		105	GND
141	TX9_n		104	RX8_n
140	TX9_p		103	RX8_p
139	GND		102	GND
138	TX8_n		101	RX7_n
137	TX8_p		100	RX7_p
136	GND		99	GND
135	TX7_n		98	RX6_n
134	TX7_p		97	RX6_p
133	GND		96	GND
132	TX6_n		95	RX5_n
131	TX6_p		94	RX5_p
130	GND		93	GND
129	TX5_n		92	RX4_n
128	TX5_p		91	RX4_p
127	GND		90	GND
126	TX4_n		89	RX3_n
125	TX4_p		88	RX3_p
124	GND		87	GND
123	TX3_n		86	RX2_n
122	TX3_p		85	RX2_p
121	GND		84	GND
120	TX2_n		83	RX1_n
119	TX2_p		82	RX1_p

118	GND		81	GND
117	TX1n		80	RX0n
116	TX1p		79	RX0p
115	GND		78	GND
114	TX0n		77	Not used
113	TX0p		76	Not used
112	GND		75	GND

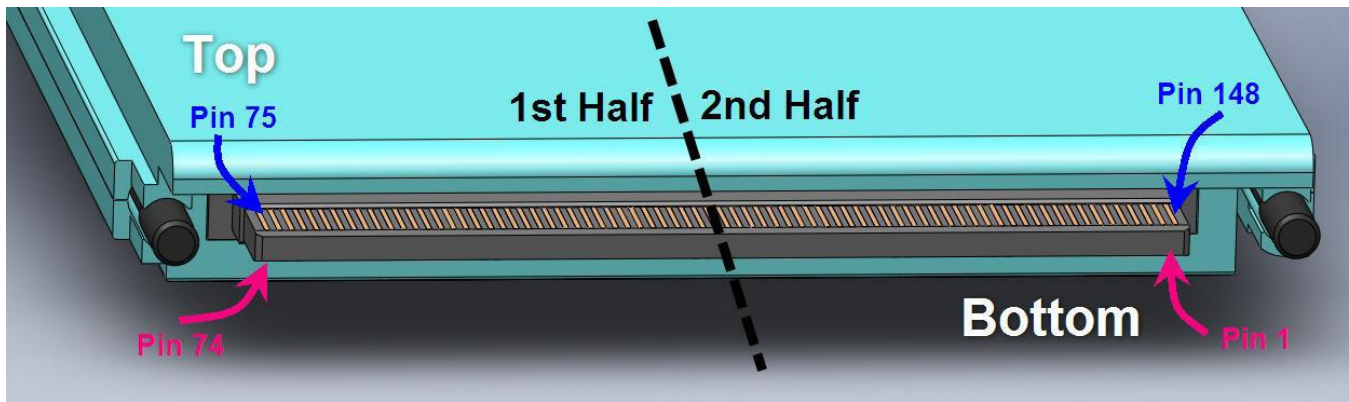

Figure3.Pad Layout of the CFP module

CFP Optical Interface lanes and Assignment

Figure 3 shows the orientation of the multimode fiber facets of the optical connector.

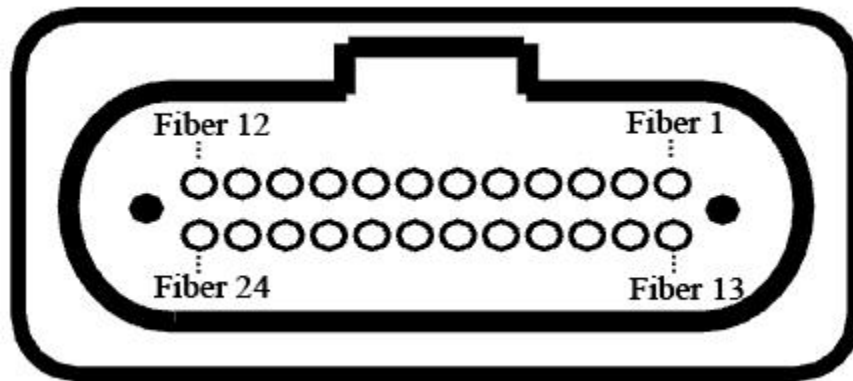

Figure4. Outside view of the CFP module MPO receptacle

Lane Assignment

Fiber	Symbol	Corresponding Electrical pins	Fiber	Symbol	Corresponding Electrical pins
1	Unused		13	Unused	
2	RX0	79,80	14	TX0	113,114
3	RX1	82,83	15	TX1	116,117
4	RX2	85,86	16	TX2	119,120
5	RX3	88,89	17	TX3	122,123

6	RX4	91,92	18	TX4	125,126
7	RX5	94,95	19	TX5	128,129
8	RX6	97,98	20	TX6	131,132
9	RX7	100,101	21	TX7	134,135
10	RX8	103,104	22	TX8	137,138
11	RX9	106,107	23	TX9	140,141
12	Unused		24	Unused	

Mechanical Dimensions

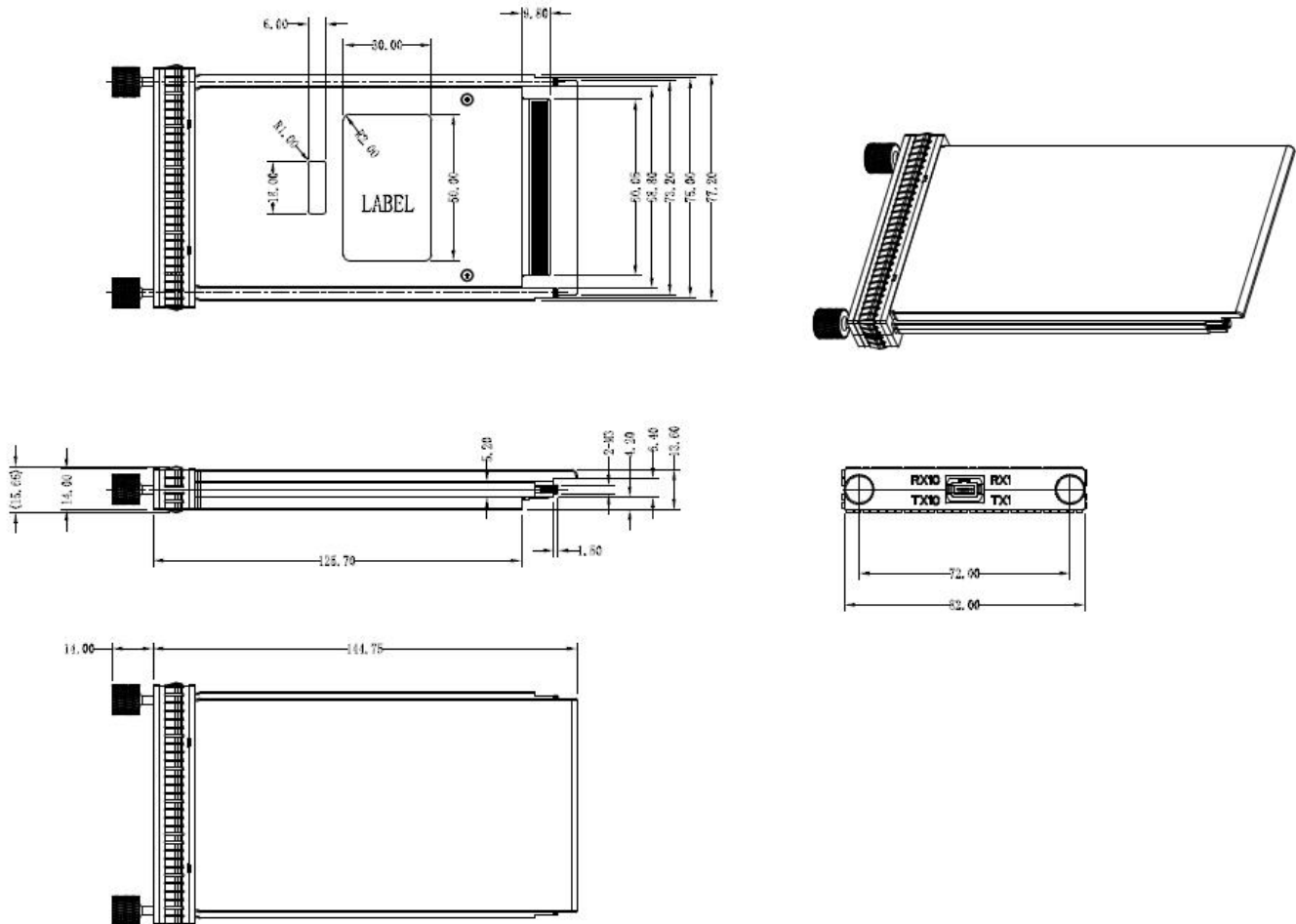

Figure5.Mechanical Specifications

Ordering information

Part Number	Product Description
GCF-M101-SR10C (with refclk)	CFP 100G SR10, 300m on OM3 MMF and 400m on OM4 MMF
GCF-M101-SR10C (without refclk)	CFP 100G SR10, 300m on OM3 MMF and 400m on OM4 MMF

Important Notice

Performance figures, data and any illustrative material provided in this data sheet are typical and must be specifically confirmed in writing by GIGALIGHT before they become applicable to any particular order or contract. In accordance with the GIGALIGHT policy of continuous improvement specifications may change without notice.

The publication of information in this data sheet does not imply freedom from patent or other protective rights of GIGALIGHT or others. Further details are available from any GIGALIGHT sales representative.

E-mail: sales@gigalight.com

Web : <http://www.gigalight.com>