

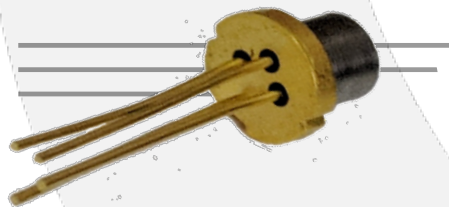

# DFB-CWDM-T



## DEVICE

## 1290 nm – 1650 nm, DFB Laser TO Can

## OVERVIEW

The DFB-CWDM-T is a CWDM TO Can DFB-LD Module for CWDM analog communication, CATV return-path, laboratory instrument, and R&D applications. Formerly known as the LDT5S51X, this cost-effective, high stability DFB laser chip has a selectable wavelength with range between 1290 nm to 1650 nm. The versatile DFB-CWDM-T also features a built-in InGaAsP monitor photodiode, built-in optical isolator and 4-pin TO Can, and a flat window emission type. Contact Optilab for more information.

## FEATURES

- Selectable wavelength: 1290 nm to 1650 nm
- Built-in InGaAsP monitor photodiode
- High-stability DFB laser chip
- 4-pin TO Can
- Built-in optical isolator

## USE IN

- CWDM analog communication
- CATV transmission return paths
- Laboratory instrument
- R&D applications

## ORDERING OPTIONS

**DFB-CWDM-T-x**  
x Wavelengths: 1290, 1310, 1330, 1350, 1370, 1390, 1410, 1410, 1430, 1450, 1470, 1490, 1510, 1530, 1550, 1570, 1590, 1610, 1650 nm

## PIN OUT DIAGRAM

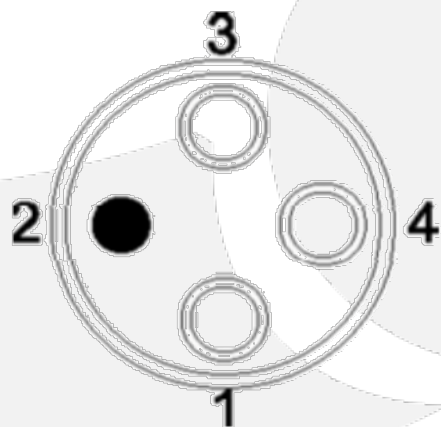

TO Can

- Pin 1 PD(-), LD(+)
- Pin 2 Case
- Pin 3 LD (-)
- Pin 4 PD(+)





# DFB-CWDM-T

## SPECIFICATIONS

Threshold Current	8 mA typ., 15 mA max.
Operating Current	70 mA max.
Analog Bandwidth	2.5 GHz typ. @ 30 mA
Monitor PD Current	50 $\mu$ J min., 2 mA max.
Monitor PD Dark Current	10 nA max.
Photodiode Capacitance	10 pF min.
RF Passband Flatness	1 dB max.
Noise Power Ratio	40/14 min. @ 25 °C
Rise/Fall Time	500 ps max. to 3 Gb/s

## ELECTRICAL

## OPTICAL

Center Wavelength Variation	$\pm$ 2 nm
Optical Isolation	20 dB
Optical Output Power	4 mW min.
Laser Linewidth	0.1 nm max.
Slope Efficiency	0.1 A/W min.
Side Mode Suppression Ratio	30 dB min.
Spurious Noise w/ Carrier	-60 dBc typ.
Spurious Noise w/out Carrier	-52 dBc typ.
Relative Intensity Noise	-150 dB/Hz max.
Emission Type	Flat Window

## MAXIMUM RATINGS

Laser Diode Reverse Voltage	2 V
Laser Diode Forward Current	110 mA
Monitor PD Reverse Voltage	15 V
Monitor PD Reverse Current	2 mA

## MECHANICAL

Operating Temperature	-20°C to +75°C
Storage Temperature	-40°C to +85°C
Power Supply Voltage	1.2 V typ., 2 V max.
Dimensions	20 mm x 5.5 mm x 5.5 mm



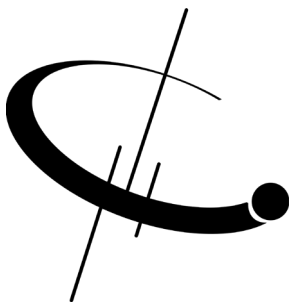

# DFB-CWDM-T

MECHANICAL DRAWING

