

LTS-16-OD

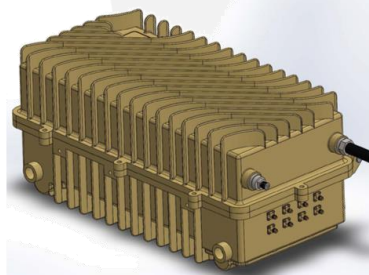

DEVICE

Lightwave Transmitter System Design for Outdoors

OVERVIEW

The Optilab LTS-16-OD is a ruggedized, fully integrated system designed for multiple channel RF over Fiber (RFoF) applications. This high density system provides an efficient platform for outdoor deployment environments with centralized control/monitoring. LTS-16-OD can accommodate up to 16 RFoF modules internally. A wide variety of Optilab modules can be integrated into this platform including Optilab LT (Lightwave Transmitter), MD (Modulator Driver), EDFA (Erbium-Doped Fiber Amplifier) and passive WDM devices in a variety of combinations. This outdoor model features redundant power supplies and a ruggedized weather resistant aluminum housing for remote location deployment. With the LTS management software, the system and module parameters may be controlled and monitored over optical fiber communication. Contact Optilab for more information.

FEATURES

- High-capacity outdoor housing for 16 modules:
 - LT (Lightwave Transmitter)
 - MD (Modulator Driver)
 - EDFA (Erbium-Doped Fiber Amplifier)
 - Passive (Mux, splitter)
- Complete customization of RFoF system
- LRS Management software for control/monitoring of all modules
- Weather resistance aluminum cast housing
- Remote control. RS-485 over fiber

USE IN

- Multiple channel RFoF system
- Multiple satellite antenna distribution
- Multiple wavelength RFoF link over single fiber

MECHANICAL DRAWING

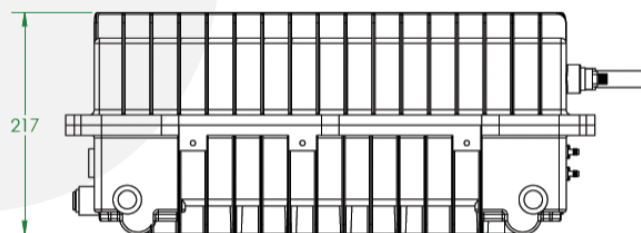
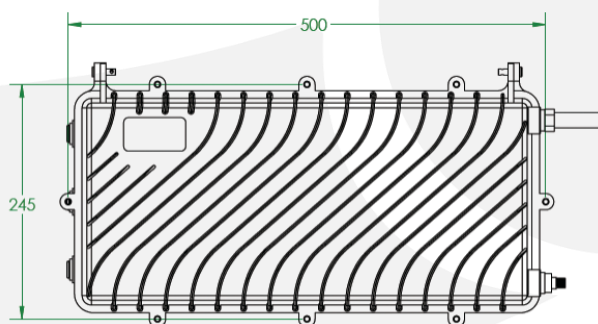

Dimensions in mm



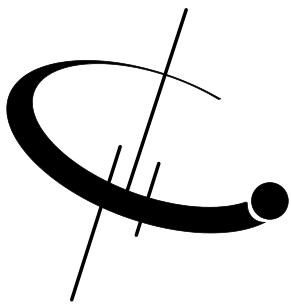

LTS-16-OD

SPECIFICATIONS

Operating Temperature	-45°C to +70°C
Storage Temperature	-55°C to +85°C
Dimensions	500mm x 245mm x 217mm
Weight	15 kg to 20 kg
Power Supply	Dual redundant
Power Requirement	110/240 VAC, 50-60 Hz, (2A max. optional), DC power supplies available

GENERAL

Local	LED for status display
Remote	Optilab LRS management software
RF Connector	K type, V type, or SMA depending upon RF requirements
Optical Connector	Armored fiber with FC/APC
Interface Connector	Armored fiber with FC/APC
Remote Control	RS-485 interface over fiber

MECHANICAL

FUNCTIONAL DIAGRAM (EXAMPLE) 8 x MD + LT SYSTEM

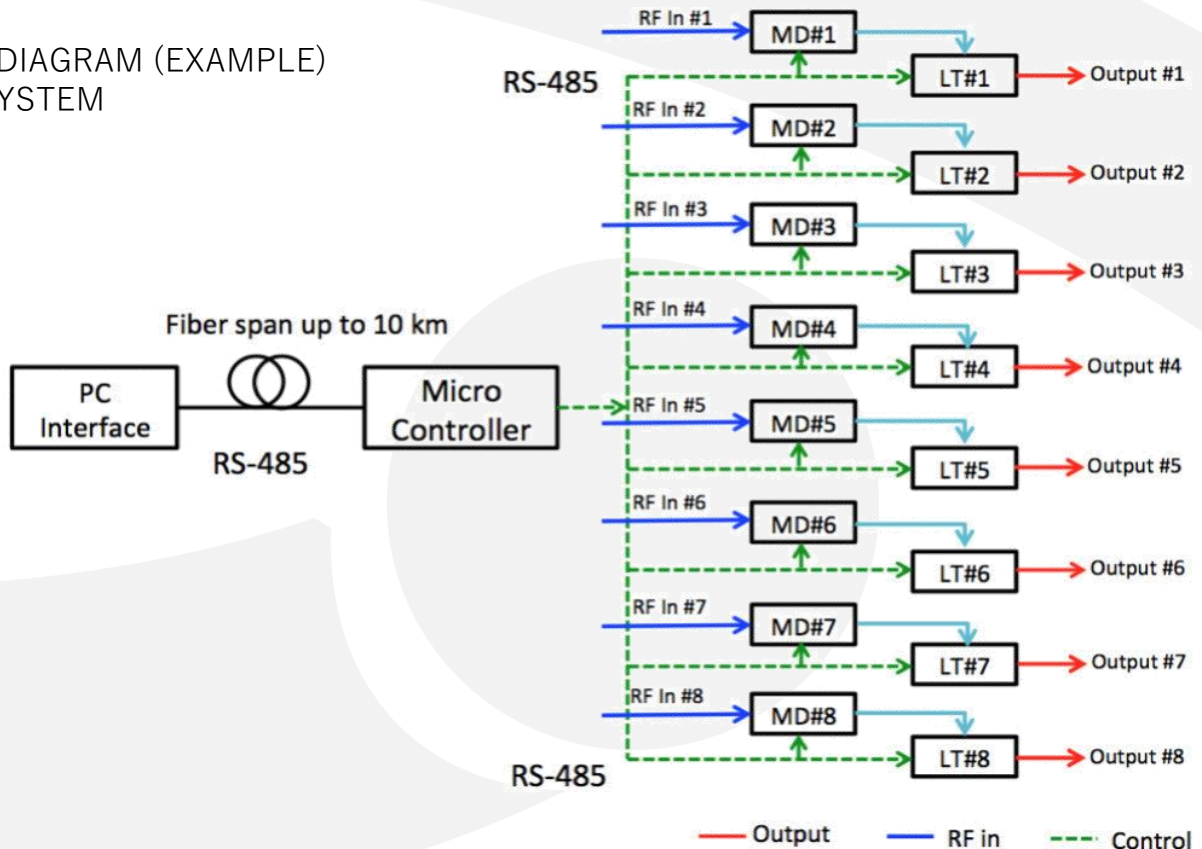

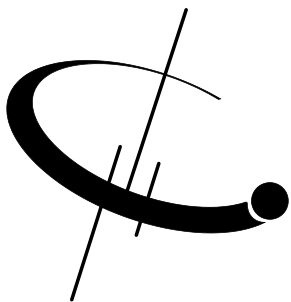

LTS-16-OD

OPTILAB'S MODULES AVAILABLE FOR INTEGRATION WITH LTS-16-OD

LT SERIES

LTB-12	12 GHz Lightwave Transmitter Board
LTB-20	20 GHz Lightwave Transmitter Board
LTB-40	40 GHz Lightwave Transmitter Board
LTB-20-LD	20 GHz Lightwave Transmitter Board, Low Drive
LTB-40-LD	40 GHz Lightwave Transmitter Board, Low Drive

MD SERIES

MD-12	12 GHz Modulator Driver/RF Amplifier
MD-20	20 GHz Modulator Driver/RF Amplifier
MD-40	40 GHz Modulator Driver/RF Amplifier
MD-50	50 GHz Modulator Driver/RF Amplifier

EDFA SERIES

EDFA-PA-M	25 dB Gain Pre-Amp EDFA Module, C-band
EDFA-18-LC-M	18 dBm EDFA Module with Low Current Consumption
EDFA-23-M	23 dBm In-Line EDFA

PASSIVE

MUX-4	4 Channel Multiplexer
MUX-16	16 Channel Multiplexer
MUX-40	40 Channel Multiplexer
SPLT-4	4 Channel Splitter
SPLT-8	8 Channel Splitter
SPLT-16	16 Channel Splitter

